

Detail of DD600 System

Model: DD600
Manufacture: Fox Environmental Systems
Max Working Pressure: 170 PSI
Grate Class: Class D Heavy Duty
RPZ: Compliant with ASSE1013

Note:
 This is a schematic representation only. Slab size and gradient to engineers details as arranged by customer. All plumbing and electrical connections to be installed by certified tradesmen in accordance with relative authorities requirements. Tradesmen to be engaged by the purchaser.

Plan View

Scale 1:20

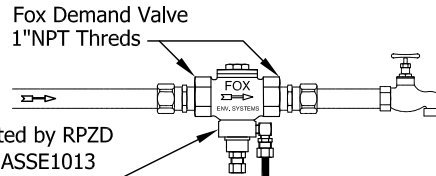
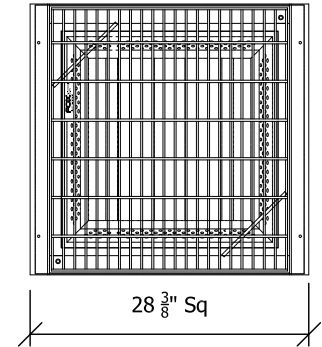

Must be protected by RPZD compliant with ASSE1013

All washdown points must come from this point.

Placement of UPC Shield

Model: DD600 **Manufacture:** Fox Environmental Systems
Max Working Pressure: 170 PSI
Grate Class: Class B Heavy Duty
RPZ: Compliant with ASSE1013

Serial No.

Install Drive Line with 90° bend to enable disconnection at valve.

Provide concrete thickening around pit.

Note: Do not distort pit walls when compacting concrete. Do not vibrate concrete near pit. If installed in bitumen a concrete collar must be provided.

Drive Line (by others)
 1/2" Ø Copper tube

24" c/o

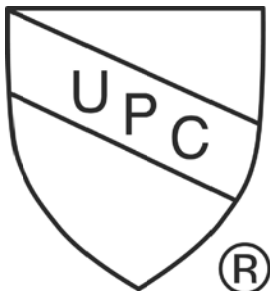
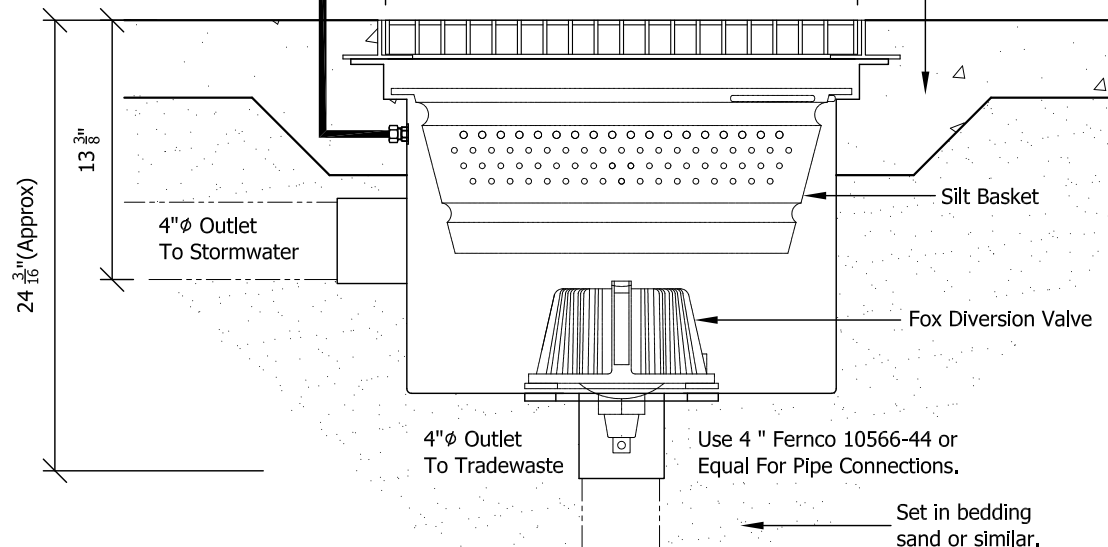

IAPMO IGC 234 2016
 File Number 10153



Project	
Drawing Title	
DD600 System	
Drawn by:	J.F.S
Date:	03/04/2019
Scale:	As Specified
Drawing No:	A4-SPEC-1003